



## BASIC OPERATION GUIDE

# DT381DF

### INTRODUCTION

The DT381DF Rugged tablet features the integration of a LED-backlit, high-brightness 800 nits 8" touchscreen and a powerful Intel® Core™ i3-N305 processor within a slim, lightweight, and durable enclosure. With the built-in Wi-Fi, BT and optional 2D barcode scanner, RFID reader, and front/back cameras options, the robust tablet offers seamless information capture and transmission for improved workflow. The DT381DF Tactical Tablet provides reliable operation in harsh, mission-critical environments.

### PACKAGE CONTENTS

- One DT381DF
- One battery pack and handstrap
- Ac-DC power adapter
- Basic operation guide

\* The actual package contents may vary depending on the configuration acquired.

## The DT381DF

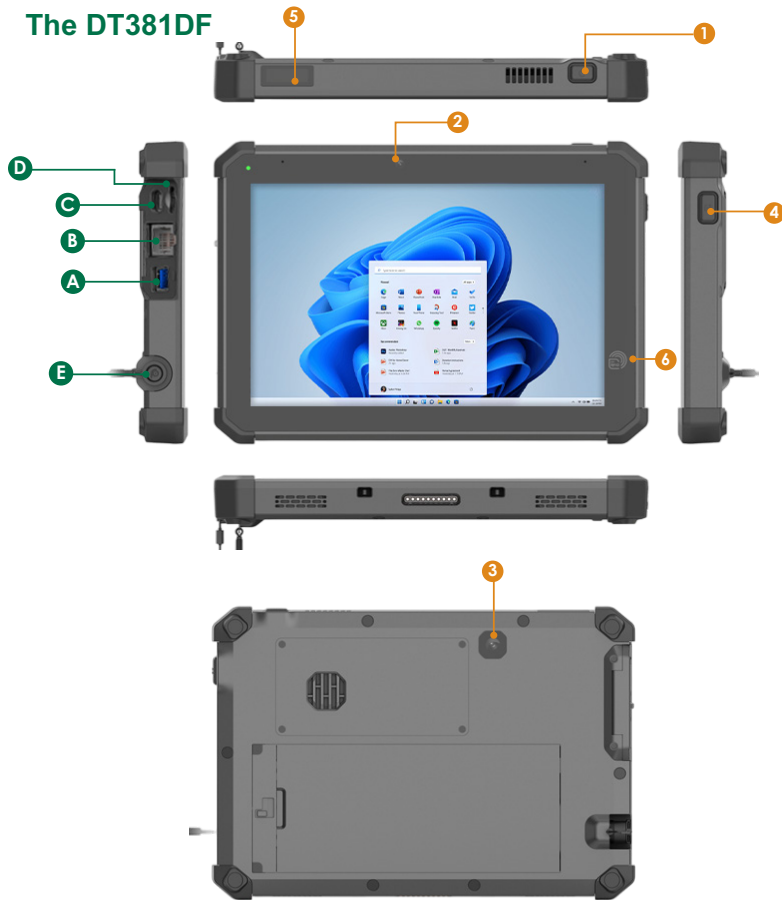

### Input/Output Ports

<b>A</b>	USB 3.2 port
<b>B</b>	LAN port
<b>C</b>	Latest USB/charging
<b>D</b>	microSD slot
<b>E</b>	24-pin Fischer Minimax connector (power 5-6A (in) and power 2A (out)/ground/URAT)

### Button Functions

BUTTON	ACTION
<b>1</b>	Power button
<b>2</b>	Front camera
<b>3</b>	Back camera (optional)
<b>4</b>	Programmable button
<b>5</b>	Brcode scanner (optional)
<b>6</b>	RFID reader (optional)

## PRECAUTIONS

- Always exercise care when operating and handling the DT381DF.
- Do NOT apply excessive pressure to the display screen.
- We recommend using the Digital Pen (optional) to keep the screen clean.
- Avoid prolonged exposure of the display panel to any strong heat source. Wherever possible, the DT381DF should face away from direct light to reduce glare.
- If the AC-DC power adapter is used to recharge or power the tablet, do NOT use any AC-DC adapter other than the one provided or acquired from the manufacturer or its partners.
- In the unlikely event that smoke, abnormal noise, or strange odor is present, immediately power off the DT381DF and disconnect all power sources. Report the problem to your device provider immediately.
- Never attempt to disassemble the DT381DF, as this will void the warranty.

### NOTE:

To obtain protection consistent with any IP rating for the device, the I/O (audio, power, USB, card reader, etc.) port doors must be closed. If the IP protection is compromised by mishandling or misuse, such as by leaving port doors open or improperly closed, any resulting product damage will not be covered under any DT Research warranty.

## BASIC FEATURES

The DT381DF rugged tablet integrates a bright display, USB ports, and embedded networking elements such as wireless LAN.

A DT381DF typically integrates an 802.11be wireless LAN (WLAN) adapter that may connect to other wireless devices or access points. If your DT381DF does not come with such a network adapter, please consult your device provider to establish the desired network connectivity.

## OPERATION

### Powering ON and OFF

To activate DT381DF, push and quickly release the Power Button. The display will come on in a few seconds. To put the DT381DF in standby mode, push and quickly release the Power Button. To turn the DT381DF off for extended storage, power off safely using any software function that “shuts down computer” provided in the software operating system.

### NOTE:

The battery packs shipped with your tablet may be low in power - please use the AC-DC adapter with the DT381DF when setting up for the first time to fully charge the battery pack.

### NOTE:

To conserve power, push and quick release the Power Button to make the tablet in standby mode while not in use. Pushing briefly on the same button will wake up the system.

## NOTE:

When the battery pack is charging, the blue-colored Battery LED should blink slowly. If plugging in the AC-DC adapter does not trigger this blinking activity and the LED stays dark, the battery pack(s) may have been drained substantially. Unplug/replug the AC-DC adapter to the DT381DF a few times to activate the charging process.

## NOTE:

Avoid using the Power Button (“hold 4+ seconds” feature) to turn off the tablet—this form of hardware shutdown is intended to be a means of recovery from lockups, and not as normal operation.

## Start Up

If the power up (from Standby mode or otherwise) is successful, the appropriate interface will be displayed after a launch sequence of several seconds. The wireless LAN connection may take 10 to 15 seconds to be established.

## Configuring the Rugged Tablet

The DT381DF may be configured using the utilities and methods dictated by the software operating system. The DT381DF should be configurable for various properties such as user profiles, network features, and several system elements.

For the convenience of the user, DT Research offers two applications to assist in the configuration of the Windows-based tablets. These comprise the Control Center and the Button Manager.

Information and instructions on these applications are available online [https://www.dtresearch.com/support/bog/RTL\\_BM\\_BOG.pdf](https://www.dtresearch.com/support/bog/RTL_BM_BOG.pdf) and [https://www.dtresearch.com/support/bog/RTL\\_CC\\_BOG.pdf](https://www.dtresearch.com/support/bog/RTL_CC_BOG.pdf).

They are also available locally on the tablet as described below:

The **Button Manager** is a graphics-based tool for managing the physical buttons on DT Research computing systems. Most of the DT Research devices have physical buttons that allow users to quickly access certain functions and features, including Barcode Scanner trigger, On-Screen keyboard, Windows Key, system volume/screen brightness adjustment, and launching of user-defined applications. Some buttons may be pre-defined out-of-the-box to accommodate common uses.

The application can be launched from the Windows System Tray by tapping on the  icon to show the corresponding configuration user interface (UI).

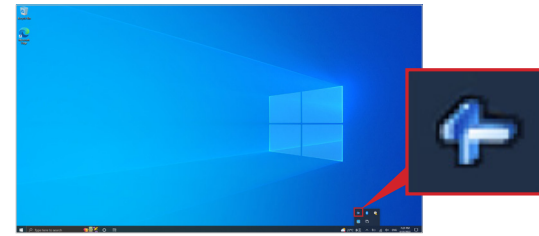

**NOTE:** User could “Press, briefly hold and release (Right-click)” the  icon to launch a pop-up menu. This pop-up menu allows user to choose from a selection of options (e.g., About, Settings, Help) related to the application and its usage.

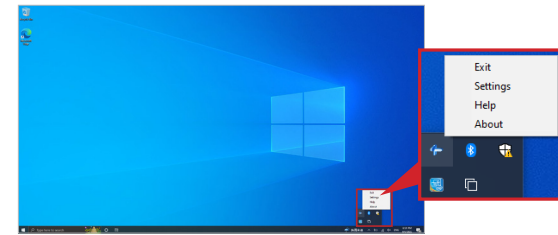

Notably, under Help, the user is able to view locally (on-device) a tutorial on the usage of the tool or application.

The **Control Center** is a custom portal for accessing major system modules and settings on DT Research systems. Authorized users may enable/disable communication (e.g., Wi-Fi and optional WWAN) and/or optional productivity modules. All users have the authority to manipulate the settings related to display brightness, screen orientation, and touch modes to accommodate specific applications and user preferences.

The application can be launched from the Windows System Tray. Tap on the Control Center icon  to launch the software.

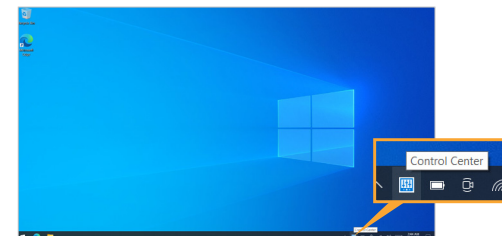

User may “Press, briefly hold and release (Right-click)” the  icon to launch a pop-up menu.

This pop-up menu allows user to choose from a selection of options (e.g., About, Help) related to the application and its usage.

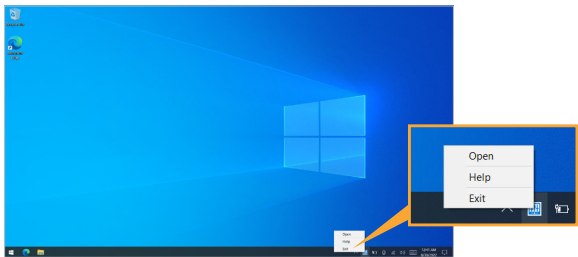

Notably, under Help, the user is able to view locally (on-device) a tutorial on the usage of the tool or application.

## Wireless Networking

### Wireless LAN

The DT381DF is often delivered with an embedded (user-inaccessible) 802.11be LAN adapter equipped with a hidden custom antenna.

- Through the support of typical WLAN adapters, the DT381DF should be able to detect all 802.11 access points in the vicinity for you to select the access point of your choice for connection.
- The SSID and WEP/WPA/WPA2 (if enabled) parameters on the DT381DF and the access points have to match. The SSID is case-sensitive and it is recommended that you enable WEP/WPA/WPA2 encryption (or advanced alternatives) for secure access.
- When WEP/WPA/WPA2 is enabled, you may need to consult your network administrator or your networking equipment literature to properly configure associated settings such as Authentication mode, etc.
- Refer to the access point operating manuals for setting up the 802.11 access points.

## USING THE TABLET

### To Hold the Tablet

Left hand: grip the left back side of the tablet with your left hand four index fingers, with thumb resting on the top of the back side of the tablet and palm securely against the back.



Right hand: grip the right back side of the tablet with your right hand four index fingers, with thumb resting on the top of the back side of the tablet and palm securely against the back.



### CAUTION:

- Disposal of a battery into fire or a hot oven, or mechanically crushing or cutting of a battery, that can result in an explosion.
- Leaving a battery in an extremely high temperature surrounding environment that can result in an explosion or the leakage of flammable liquid or gas.

## Battery Usage and Maintenance

DT Research tablets and laptops are powered by lithium polymer battery packs in proprietary form factors. Battery configurations for the DT Research devices include internal (bridge or backup), removable or swappable implementations.

Battery usage cycles, or duration between necessary re-charge, vary with a number of factors, including device model, device usage pattern and battery health/aging. The DTR battery packs may be charged while attached to the device or when separated from the device and docked in proprietary battery charging cradles. Following the guidelines on good practice below can help to keep a battery pack healthy and prolong battery usage cycles and battery lifespan.

- Avoid high heat conditions during operation, idle, charging, and storage states.
- Avoid letting the battery pack remain in very highly charged state or overly low charged state for extensive periods of time. Keeping the battery capacity between 30% and 80% of maximum capacity is recommended. The prevailing battery level(s) can be read from the Battery utility within the Windows operating system.
- Avoid letting the battery be over-discharged or depleted. Over-discharge can occur when a fully-discharged (0% level or thereabouts) battery pack is allowed to remain in such a state for an extended period of time (weeks or months). The embedded battery controls enter a protection mode and recharging will be prevented for safety reasons. To reduce the likelihood of over-discharge, consider recharging idle batteries regularly to some level between 30% to 80% of capacity.
- For long term storage, it is recommended that removable battery packs be stored separated from the device. Otherwise, the system should be placed in Shutdown mode. The battery level will decrease with time and it is recommended that the battery packs be monitored or recharged every 2 to 3 months to maintain.

## Federal Communication Commission Interference

This equipment has been tested and found to comply with the limits for a Class B digital device, pursuant to Part 15 of the FCC Rules. These limits are designed to provide reasonable protection against harmful interference in a residential installation. This equipment generates, uses and can radiate radio frequency energy and, if not installed and used in accordance with the instructions, may cause harmful interference to radio communications. However, there is no guarantee that interference will not occur in a particular installation. If this equipment does cause harmful interference to radio or television reception, which can be determined by turning the equipment off and on, the user is encouraged to try to correct the interference by one of the following measures:

- Reorient or relocate the receiving antenna.
- Increase the separation between the equipment and receiver.
- Connect the equipment into an outlet on a circuit different from that to which the receiver is connected.
- Consult the dealer or an experienced radio/TV technician for help.

FCC Caution: Any changes or modifications not expressly approved by the party responsible for compliance could void the user's authority to operate this equipment.

This device complies with Part 15 of the FCC Rules.

Operation is subject to the following two conditions: (1) This device may not cause harmful interference, and (2) this device must accept any interference received, including interference that may cause undesired operation.

This device and its antenna(s) must not be co-located or operating in conjunction with any other antenna or transmitter.

This Class [B] digital apparatus complies with Canadian ICES-003.

Cet appareil numérique de la classe [B] est conforme à la norme NMB-003 du Canada.

## For More Support

Users can download the Tablet Modules Basic Operation Guides from the DT Research website.

## WM281 Wall Mount Cradle Installation Guide

1. Use the key to unlock, and slide the latch on the bottom of the Cradle to loosen the Top Clasp.
2. Insert the bottom part of the Tablet into the cradle first with the connector parts correctly lined up.
3. When the bottom of the Tablet is in place, push the Tablet against the back and into the Cradle.
4. Push down on the Top Clasp, so the top portion of the cradle slides down and locks into the locked-down position.
5. Lock the Cradle with the key.



## OPERATION

### Mounting the Cradle

The Tablet Mount Cradle supports VESA standard mounting options (75 mm x 75 mm or 100 mm x 100 mm) so it can be easily attached onto a wall, in a vehicle, and on a VESA arm.

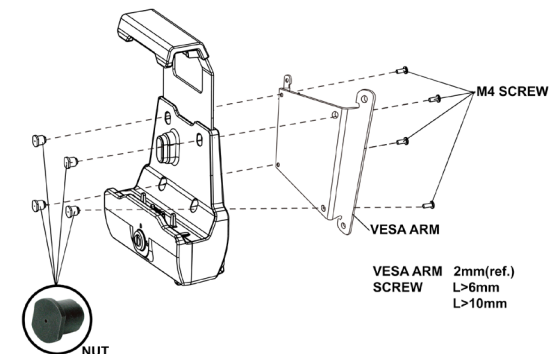

**NOTE:** If using a 100 x 100 VESA stand or arm, the VESA Conversion Bracket is needed. Please place the VESA Conversion Bracket on the back side of the Cradle, and apply the four M4 screws.